

# **INVOIC Invoice message**

**EDIFACT/D98B/INVOIC: INVOIC Invoice message**

**Version: 1.0 Final**

<b>Author:</b>	<b>DSV EDI team</b>
<b>Company:</b>	<b>DSV</b>
<b>Publication:</b>	<b>16-04-2010</b>

# Table of Contents

<b>INVOIC</b>	<b>Invoice message</b> .....	<b>1</b>
	<b>Branching Diagram - 1</b> .....	<b>3</b>
	<b>Branching Diagram - 2</b> .....	<b>4</b>
	<b>Branching Diagram - 3</b> .....	<b>5</b>
	<b>Branching Diagram - 4</b> .....	<b>6</b>
<b>UNB</b>	<b>INTERCHANGE HEADER</b> .....	<b>7</b>
<b>UNH</b>	<b>MESSAGE HEADER</b> .....	<b>9</b>
<b>BGM</b>	<b>BEGINNING OF MESSAGE</b> .....	<b>10</b>
<b>DTM</b>	<b>DATE/TIME/PERIOD</b> .....	<b>11</b>
<b>Group 2</b>	<b>Segment Group 2</b> .....	<b>12</b>
<b>NAD</b>	<b>NAME AND ADDRESS</b> .....	<b>13</b>
<b>Group 3</b>	<b>Segment Group 3</b> .....	<b>15</b>
<b>RFF</b>	<b>REFERENCE</b> .....	<b>16</b>
<b>Group 7</b>	<b>Segment Group 7</b> .....	<b>17</b>
<b>CUX</b>	<b>CURRENCIES</b> .....	<b>18</b>
<b>Group 8</b>	<b>Segment Group 8</b> .....	<b>19</b>
<b>PAT</b>	<b>PAYMENT TERMS BASIS</b> .....	<b>20</b>
<b>DTM</b>	<b>DATE/TIME/PERIOD</b> .....	<b>21</b>
<b>Group 26</b>	<b>Segment Group 26</b> .....	<b>22</b>
<b>LIN</b>	<b>LINE ITEM</b> .....	<b>23</b>
<b>MEA</b>	<b>MEASUREMENTS</b> .....	<b>24</b>
<b>Group 27</b>	<b>Segment Group 27</b> .....	<b>25</b>
<b>MOA</b>	<b>MONETARY AMOUNT</b> .....	<b>26</b>
<b>Group 30</b>	<b>Segment Group 30</b> .....	<b>27</b>
<b>RFF</b>	<b>REFERENCE</b> .....	<b>28</b>
<b>Group 31</b>	<b>Segment Group 31</b> .....	<b>29</b>
<b>PAC</b>	<b>PACKAGE</b> .....	<b>30</b>
<b>Group 35</b>	<b>Segment Group 35</b> .....	<b>31</b>
<b>NAD</b>	<b>NAME AND ADDRESS</b> .....	<b>32</b>
<b>Group 39</b>	<b>Segment Group 39</b> .....	<b>34</b>
<b>ALC</b>	<b>ALLOWANCE OR CHARGE</b> .....	<b>35</b>
<b>Group 42</b>	<b>Segment Group 42</b> .....	<b>36</b>
<b>MOA</b>	<b>MONETARY AMOUNT</b> .....	<b>37</b>
<b>Group 44</b>	<b>Segment Group 44</b> .....	<b>38</b>
<b>TAX</b>	<b>DUTY/TAX/FEE DETAILS</b> .....	<b>39</b>
<b>UNS</b>	<b>SECTION CONTROL</b> .....	<b>41</b>
<b>Group 50</b>	<b>Segment Group 50</b> .....	<b>42</b>
<b>MOA</b>	<b>MONETARY AMOUNT</b> .....	<b>43</b>
<b>Group 52</b>	<b>Segment Group 52</b> .....	<b>44</b>
<b>TAX</b>	<b>DUTY/TAX/FEE DETAILS</b> .....	<b>45</b>
<b>UNT</b>	<b>MESSAGE TRAILER</b> .....	<b>47</b>
<b>UNZ</b>	<b>INTERCHANGE TRAILER</b> .....	<b>48</b>

# INVOIC Invoice message

Message Status=2

## Not Defined:

<u>Pos</u>	<u>Tag</u>	<u>Segment Name</u>	<u>Status</u>	<u>Rep</u>	<u>Notes</u>	<u>Usage</u>
	UNB	INTERCHANGE HEADER	M	1		Must use

## Heading:

<u>Pos</u>	<u>Tag</u>	<u>Segment Name</u>	<u>Status</u>	<u>Rep</u>	<u>Notes</u>	<u>Usage</u>
0010	UNH	MESSAGE HEADER	M	1	N1/0010	Must use
0020	BGM	BEGINNING OF MESSAGE	M	1	N1/0020	Must use
0030	DTM	DATE/TIME/PERIOD	M	35	N1/0030	Must use
<b>0200</b>		<b>Segment Group 2</b>	<b>C</b>	<b>99</b>	<b>N1/0200</b>	<b>Must use</b>
0210	NAD	NAME AND ADDRESS	M	1	N1/0210	Must use
<b>0240</b>		<b>Segment Group 3</b>	<b>C</b>	<b>9999</b>	<b>N1/0240</b>	<b>Used</b>
0250	RFF	REFERENCE	M	1	N1/0250	Must use
<b>0370</b>		<b>Segment Group 7</b>	<b>C</b>	<b>99</b>	<b>N1/0370</b>	<b>Must use</b>
0380	CUX	CURRENCIES	M	1	N1/0380	Must use
<b>0400</b>		<b>Segment Group 8</b>	<b>C</b>	<b>10</b>	<b>N1/0400</b>	<b>Must use</b>
0410	PAT	PAYMENT TERMS BASIS	M	1	N1/0410	Must use
0420	DTM	DATE/TIME/PERIOD	C	5	N1/0420	Must use

## Detail:

<u>Pos</u>	<u>Tag</u>	<u>Segment Name</u>	<u>Status</u>	<u>Rep</u>	<u>Notes</u>	<u>Usage</u>
<b>1060</b>		<b>Segment Group 26</b>	<b>C</b>	<b>9999999</b>	<b>N2/1060</b>	<b>Must use</b>
1070	LIN	LINE ITEM	M	1	N2/1070	Must use
1100	MEA	MEASUREMENTS	C	5	N2/1100	Must use
<b>1210</b>		<b>Segment Group 27</b>	<b>C</b>	<b>10</b>	<b>N2/1210</b>	<b>Must use</b>
1220	MOA	MONETARY AMOUNT	M	1	N2/1220	Must use
<b>1350</b>		<b>Segment Group 30</b>	<b>C</b>	<b>10</b>	<b>N2/1350</b>	<b>Must use</b>
1360	RFF	REFERENCE	M	1	N2/1360	Must use
<b>1380</b>		<b>Segment Group 31</b>	<b>C</b>	<b>10</b>	<b>N2/1380</b>	<b>Must use</b>
1390	PAC	PACKAGE	M	1	N2/1390	Must use
<b>1550</b>		<b>Segment Group 35</b>	<b>C</b>	<b>99</b>	<b>N2/1550</b>	<b>Must use</b>
1560	NAD	NAME AND ADDRESS	M	1	N2/1560	Must use
<b>1670</b>		<b>Segment Group 39</b>	<b>C</b>	<b>30</b>	<b>N2/1670</b>	<b>Must use</b>
1680	ALC	ALLOWANCE OR CHARGE	M	1	N2/1680	Must use
<b>1780</b>		<b>Segment Group 42</b>	<b>C</b>	<b>2</b>	<b>N2/1780</b>	<b>Must use</b>
1790	MOA	MONETARY AMOUNT	M	1	N2/1790	Must use
<b>1860</b>		<b>Segment Group 44</b>	<b>C</b>	<b>5</b>	<b>N2/1860</b>	<b>Must use</b>
1870	TAX	DUTY/TAX/FEE DETAILS	M	1	N2/1870	Must use

## Summary:

<u>Pos</u>	<u>Tag</u>	<u>Segment Name</u>	<u>Status</u>	<u>Rep</u>	<u>Notes</u>	<u>Usage</u>
2120	UNS	SECTION CONTROL	M	1	N3/2120	Must use

<u>Pos</u>	<u>Tag</u>	<u>Segment Name</u>	<u>Status</u>	<u>Rep</u>	<u>Notes</u>	<u>Usage</u>
<b>2140</b>		<b>Segment Group 50</b>	<b>M</b>	<b>100</b>	<b>N3/2140</b>	<b>Must use</b>
2150	MOA	MONETARY AMOUNT	M	1	N3/2150	Must use
<b>2190</b>		<b>Segment Group 52</b>	<b>C</b>	<b>10</b>	<b>N3/2190</b>	<b>Must use</b>
2200	TAX	DUTY/TAX/FEE DETAILS	M	1	N3/2200	Must use
2270	UNT	MESSAGE TRAILER	M	1	N3/2270	Must use

**Not Defined:**

<u>Pos</u>	<u>Tag</u>	<u>Segment Name</u>	<u>Status</u>	<u>Rep</u>	<u>Notes</u>	<u>Usage</u>
	UNZ	INTERCHANGE TRAILER	M	1		Must use

**Message example for customer:**

UNA:+. ? '  
 UNB+UNOA:1+5790000834129+5790001215323FH+100303:2124+932'  
 UNH+1+INVOIC:D:98B:UN'  
 BGM+380+HS457187+9'  
 DTM+137:20100303:102'  
 DTM+2:201003050000:203'  
 NAD+IV+050000165474::91++MAN DIESEL+NIELS JUELS VEJ 15+FREDERIKSHAVN++9900+DK'  
 NAD+II+KEYHO - DSV Road A/S+NOKIAVEJ 30, LUND+HORSENS++8700+DK'  
 RFF+VA:26366224'  
 CUX+2:DKK:10+3:DKK:11+1000000'  
 PAT+3'  
 DTM+13:20100428:102'  
 LIN+1'  
 MEA+WT+AAD+KGM:68.000'  
 MEA+CHW++KGM:79.587'  
 MEA+VOL++CBM:0.239'  
 MEA+LMT++MTR:0.000'  
 MOA+203:372.000:DKK'  
 RFF+BN:KEYHO-47497'  
 RFF+CU:0001320194'  
 PAC+2++CLL'  
 NAD+CZ+050000165474++MAN DIESEL+NIELS JUELS VEJ 15+FREDERIKSHAVN++9900+DK'  
 NAD+PW+050000165474++MAN DIESEL+NIELS JUELS VEJ 15+FREDERIKSHAVN++9900+DK'  
 NAD+CN+000000000000++VAN ESCH SSL++ROTTERDAM++3089 KB+NL'  
 NAD+DP+++VAN ESCH SSL++ROTTERDAM++3089 KB+NL'  
 ALC+C+:6+++ACT::87:FRAGT'  
 MOA+8:277.000:DKK'  
 MOA+124:69.250:DKK'  
 TAX+7+VAT+++::25,0000+S'  
 ALC+C+:6+++ACT::87:KAM FEE'  
 MOA+8:95.000:DKK'  
 MOA+124:23.750:DKK'  
 TAX+7+VAT+++::25,0000+S'  
 UNS+S'  
 MOA+125:372.000:DKK'  
 MOA+86:465.000:DKK'  
 MOA+176:93.000:DKK'  
 TAX+7+VAT+++::25,0000+S'  
 UNT+37+1'  
 UNZ+1+932'

**Branching Diagram** : INVOIC(Invoice message)

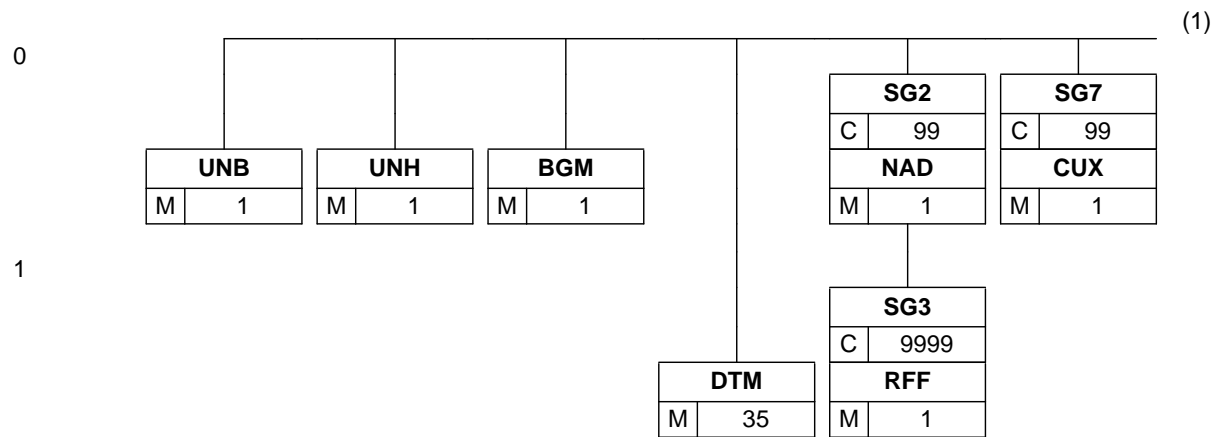

**Branching Diagram : INVOIC(Invoice message)**

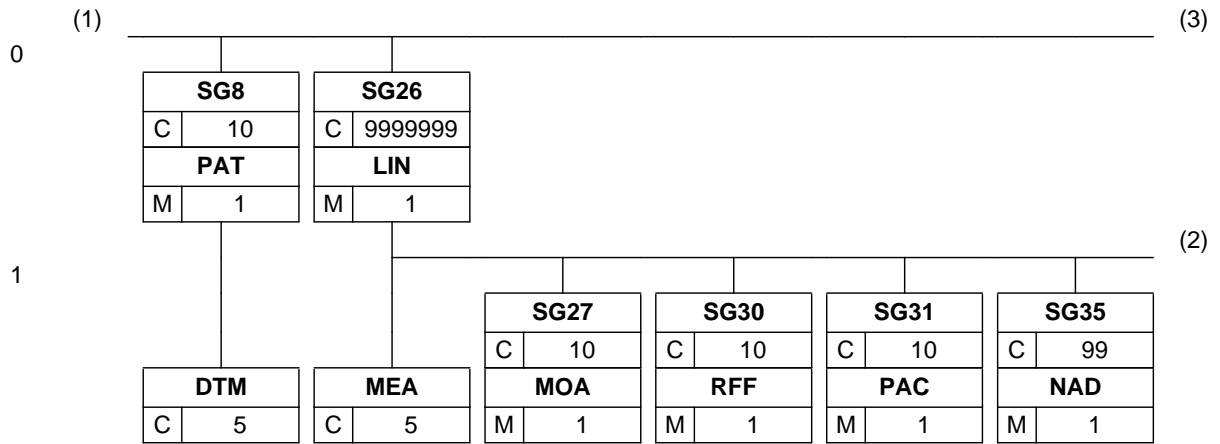

**Branching Diagram : INVOIC(Invoice message)**

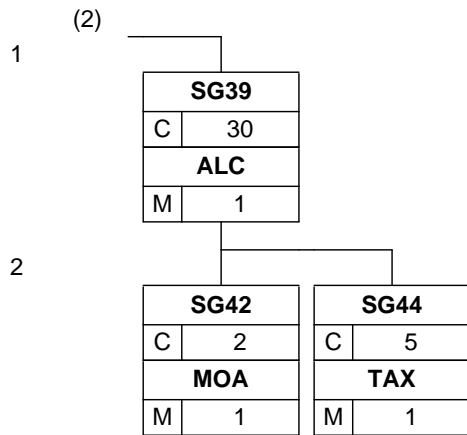

**Branching Diagram** : INVOIC(Invoice message)

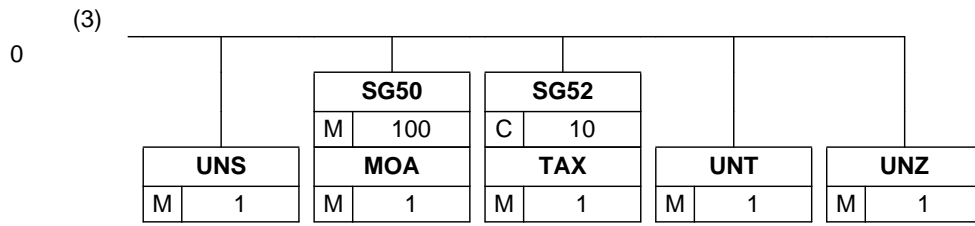



**UNB INTERCHANGE HEADER**

Pos:	Max: 1
Mandatory	
Group:	Elements: 11
N/A	

**User Option (Usage):** Must use

**Purpose:** To start, identify and specify an interchange.

**Element Summary:**

<u>Ref</u>	<u>Tag</u>	<u>Element Name</u>	<u>Status</u>	<u>Type</u>	<u>Min/Max</u>	<u>Usage</u>
UNB010	S001	<b>SYNTAX IDENTIFIER</b>	M	Comp		Must use
UNB010-01 0	0001	<b>Syntax identifier</b>	M	a	4/4	Must use
<b>CodeList Summary</b> (Total Codes: 6, Included: 1)						
<b>Code Name</b>						
UNOA UN/ECE level A						
UNB010-02 0	0002	<b>Syntax version number</b>	M	n	1/1	Must use
<b>CodeList Summary</b> (Total Codes: 3, Included: 1)						
<b>Code Name</b>						
1 Version 1						
UNB020	S002	<b>INTERCHANGE SENDER</b>	M	Comp		Must use
UNB020-01 0	0004	<b>Sender identification</b>	M	an	1/35	Must use
* UNB020-02 0	0007	<b>Partner identification code qualifier</b>	C	an	1/4	Not used
* UNB020-03 0	0008	<b>Address for reverse routing</b>	C	an	1/14	Not used
UNB030	S003	<b>INTERCHANGE RECIPIENT</b>	M	Comp		Must use
UNB030-01 0	0010	<b>Recipient identification</b>	M	an	1/35	Must use
* UNB030-02 0	0007	<b>Partner identification code qualifier</b>	C	an	1/4	Not used
* UNB030-03 0	0014	<b>Routing address</b>	C	an	1/14	Not used
UNB040	S004	<b>DATE/TIME OF PREPARATION</b>	M	Comp		Must use
UNB040-01 0	0017	<b>Date of preparation</b>	M	n	6/6	Must use
UNB040-02 0	0019	<b>Time of preparation</b>	M	n	4/4	Must use
UNB050	0020	<b>Interchange control reference</b>	M	an	1/14	Must use
* UNB060	S005	<b>RECIPIENTS REFERENCE PASSWORD</b>	C	Comp		Not used
* UNB060-01 0	0022	<b>Recipient's reference/password</b>	M	an	1/14	Not used
* UNB060-02 0	0025	<b>Recipient's reference/password qualifier</b>	C	an	2/2	Not used

<u>Ref</u>	<u>Tag</u>	<u>Element Name</u>	<u>Status</u>	<u>Type</u>	<u>Min/Max</u>	<u>Usage</u>
* UNB070	0026	Application reference	C	an	1/14	Not used
* UNB080	0029	Processing priority code	C	a	1/1	Not used
* UNB090	0031	Acknowledgement request	C	n	1/1	Not used
* UNB100	0032	Cummunications agreement ID	C	an	1/35	Not used
* UNB110	0035	Test indicator	C	n	1/1	Not used

**Segment example for customer:**

*UNB+UNOA:1+5790000834129+5790001215323FH+100303:2124+932'*

**UNH MESSAGE HEADER**

Pos: 0010	Max: 1
Mandatory	
Group: N/A	Elements: 4

**User Option (Usage):** Must use

**Purpose:** To head, identify and specify a message.

**Element Summary:**

<u>Ref</u>	<u>Tag</u>	<u>Element Name</u>	<u>Status</u>	<u>Type</u>	<u>Min/Max</u>	<u>Usage</u>
UNH010	0062	<b>Message reference number</b>	M	an	1/14	Must use
UNH020	S009	<b>MESSAGE IDENTIFIER</b>	M	Comp		Must use
UNH020-01 0	0065	<b>Message type identifier</b>	M	an	1/6	Must use
<b>CodeList Summary</b> (Total Codes: 172, Included: 1)						
<b><u>Code</u> <u>Name</u></b>						
INVOIC Invoice message						
UNH020-02 0	0052	<b>Message type version number</b>	M	an	1/3	Must use
<b>CodeList Summary</b> (Total Codes: 7, Included: 1)						
<b><u>Code</u> <u>Name</u></b>						
D Draft version						
UNH020-03 0	0054	<b>Message type release number</b>	M	an	1/3	Must use
<b>CodeList Summary</b> (Total Codes: 18, Included: 1)						
<b><u>Code</u> <u>Name</u></b>						
98B Release 1998 - B						
UNH020-04 0	0051	<b>Controlling agency</b>	M	an	1/2	Must use
<b>CodeList Summary</b> (Total Codes: 22, Included: 1)						
<b><u>Code</u> <u>Name</u></b>						
UN UN/ECE/TRADE/WP.4, United Nations Standard Messages (UNSM)						
* UNH020-05 0	0057	<b>Association assigned code</b>	C	an	1/6	Not used
* UNH030	0068	<b>Common access reference</b>	C	an	1/35	Not used
* UNH040	S010	<b>STATUS OF THE TRANSFER</b>	C	Comp		Not used
* UNH040-01 0	0070	<b>Sequence message transfer number</b>	M	n	1/2	Not used
* UNH040-02 0	0073	<b>First/last sequence message transfer indication</b>	C	a	1/1	Not used

**Segment example for customer:**

*UNH+1+INVOIC:D:98B:UN'*

# BGM BEGINNING OF MESSAGE

Pos: 0020	Max: 1
Mandatory	
Group:	Elements: 4
N/A	

**User Option (Usage):** Must use

**Purpose:** To indicate the type and function of a message and to transmit the identifying number.

## Element Summary:

<u>Ref</u>	<u>Tag</u>	<u>Element Name</u>	<u>Status</u>	<u>Type</u>	<u>Min/Max</u>	<u>Usage</u>
BGM010	C002	DOCUMENT/MESSAGE NAME	C	Comp		Must use
BGM010-01 0	1001	Document/message name, coded	C	an	1/3	Must use
<b>CodeList Summary</b> (Total Codes: 494, Included: 2)						
<b>Code Name</b>						
380 Commercial invoice						
780 Credit note						
* BGM010-02 0	1131	Code list qualifier	C	an	1/3	Not used
* BGM010-03 0	3055	Code list responsible agency, coded	C	an	1/3	Not used
* BGM010-04 0	1000	Document/message name	C	an	1/35	Not used
BGM020	C106	DOCUMENT/MESSAGE IDENTIFICATION	C	Comp		Must use
BGM020-01 0	1004	Document/message number	C	an	1/35	Must use
* BGM020-02 0	1056	Version	C	an	1/9	Not used
* BGM020-03 0	1060	Revision number	C	an	1/6	Not used
BGM030	1225	Message function, coded	C	an	1/3	Must use
<b>CodeList Summary</b> (Total Codes: 59, Included: 1)						
<b>Code Name</b>						
9 Original						
* BGM040	4343	Response type, coded	C	an	1/3	Not used

## Segment example for customer:

BGM+380+HS457187+9'

# DTM DATE/TIME/PERIOD

Pos: 0030	Max: 35
Mandatory	
Group: N/A	Elements: 1

**User Option (Usage):** Must use

**Purpose:** To specify date, and/or time, or period.

## Element Summary:

<u>Ref</u>	<u>Tag</u>	<u>Element Name</u>	<u>Status</u>	<u>Type</u>	<u>Min/Max</u>	<u>Usage</u>
DTM010	C507	DATE/TIME/PERIOD	M	Comp		Must use
DTM010-01 0	2005	Date/time/period qualifier	M	an	1/3	Must use

**CodeList Summary** (Total Codes: 485, Included: 2)

<u>Code</u>	<u>Name</u>
2	Delivery date/time, requested
137	Document/message date/time

DTM010-02 0	2380	Date/time/period	C	an	1/35	Must use
DTM010-03 0	2379	Date/time/period format qualifier	C	an	1/3	Must use

**CodeList Summary** (Total Codes: 71, Included: 2)

<u>Code</u>	<u>Name</u>
102	CCYYMMDD
203	CCYYMMDDHHMM

## Segment example for customer:

*DTM+137:20100303:102'*  
*DTM+2:201003050000:203'*

## Segment Group 2

Pos: 0200	Repeat: 99
Conditional	
Group: 2	Elements: N/A

**User Option (Usage):** Must use

**Purpose:**

### Segment Group Summary:

<u>Pos</u>	<u>Tag</u>	<u>Segment Name</u>	<u>Status</u>	<u>Rep</u>	<u>Usage</u>
0210	NAD	NAME AND ADDRESS	M	1	Must use
0240		Segment Group 3	C	9999	Used

# NAD NAME AND ADDRESS

Pos: 0210	Max: 1
Mandatory	
Group: 2	Elements: 9

**User Option (Usage):** Must use

**Purpose:** To specify the name/address and their related function, either by CO82 only and/or unstructured by CO58 or structured by CO80 thru 3207.

## Element Summary:

<u>Ref</u>	<u>Tag</u>	<u>Element Name</u>	<u>Status</u>	<u>Type</u>	<u>Min/Max</u>	<u>Usage</u>
NAD010	3035	Party qualifier	M	an	1/3	Must use
<b>CodeList Summary</b> (Total Codes: 375, Included: 2)						
<b>Code Name</b>						
II Issuer of invoice						
IV Invoicee						
NAD020	C082	<b>PARTY IDENTIFICATION DETAILS</b>	C	Comp		Used
NAD020-01 0	3039	Party identification	M	an	1/35	Must use
* NAD020-02 0	1131	Code list qualifier	C	an	1/3	Not used
NAD020-03 0	3055	Code list responsible agency, coded	C	an	1/3	Must use
<b>CodeList Summary</b> (Total Codes: 223, Included: 1)						
<b>Code Name</b>						
91 Assigned by seller or seller's agent						
* NAD030	C058	<b>NAME AND ADDRESS</b>	C	Comp		Not used
* NAD030-01 0	3124	Name and address line	M	an	1/35	Not used
* NAD030-02 0	3124	Name and address line	C	an	1/35	Not used
* NAD030-03 0	3124	Name and address line	C	an	1/35	Not used
* NAD030-04 0	3124	Name and address line	C	an	1/35	Not used
* NAD030-05 0	3124	Name and address line	C	an	1/35	Not used
NAD040	C080	<b>PARTY NAME</b>	C	Comp		Must use
NAD040-01 0	3036	Party name	M	an	1/35	Must use
* NAD040-02 0	3036	Party name	C	an	1/35	Not used
* NAD040-03 0	3036	Party name	C	an	1/35	Not used
* NAD040-04 0	3036	Party name	C	an	1/35	Not used
* NAD040-05 0	3036	Party name	C	an	1/35	Not used

<u>Ref</u>	<u>Tag</u>	<u>Element Name</u>	<u>Status</u>	<u>Type</u>	<u>Min/Max</u>	<u>Usage</u>
* NAD040-06 0	3045	Party name format, coded	C	an	1/3	Not used
NAD050	C059	STREET	C	Comp		Must use
NAD050-01 0	3042	Street and number/p.o. box	M	an	1/35	Must use
* NAD050-02 0	3042	Street and number/p.o. box	C	an	1/35	Not used
* NAD050-03 0	3042	Street and number/p.o. box	C	an	1/35	Not used
* NAD050-04 0	3042	Street and number/p.o. box	C	an	1/35	Not used
NAD060	3164	City name	C	an	1/35	Must use
* NAD070	3229	Country sub-entity identification	C	an	1/9	Not used
NAD080	3251	Postcode identification	C	an	1/9	Must use
NAD090	3207	Country, coded	C	an	1/3	Must use

### Segment example for customer:

*NAD+IV+050000165474::91++MAN DIESEL+NIELS JUELS VEJ 15+FREDERIKSHAVN++9900+DK'  
NAD+II+++KEYHO - DSV Road A/S+NOKIAVEJ 30, LUND+HORSENS++8700+DK'*



---

## Segment Group 3

Pos: 0240	Repeat: 9999
Conditional	
Group: 3	Elements: N/A

User Option (Usage): Used

Purpose:

### Segment Group Summary:

<u>Pos</u>	<u>Tag</u>	<u>Segment Name</u>	<u>Status</u>	<u>Rep</u>	<u>Usage</u>
0250	RFF	REFERENCE	M	1	Must use

# RFF REFERENCE

Pos: 0250	Max: 1
Mandatory	
Group: 3	Elements: 1

**User Option (Usage):** Must use

**Purpose:** To specify a reference.

## Element Summary:

<u>Ref</u>	<u>Tag</u>	<u>Element Name</u>	<u>Status</u>	<u>Type</u>	<u>Min/Max</u>	<u>Usage</u>
RFF010	C506	REFERENCE	M	Comp		Must use
RFF010-010	1153	Reference qualifier	M	an	1/3	Must use
<b>CodeList Summary</b> (Total Codes: 618, Included: 1)						
<b>Code Name</b>						
VA VAT registration number						
RFF010-020	1154	Reference number	C	an	1/35	Must use
* RFF010-030	1156	Line number	C	an	1/6	Not used
* RFF010-040	4000	Reference version number	C	an	1/35	Not used
* RFF010-050	1060	Revision number	C	an	1/6	Not used

## Segment example for customer:

*RFF+VA:26366224'*

---

# Segment Group 7

Pos: 0370	Repeat: 99
Conditional	
Group: 7	Elements: N/A

User Option (Usage): Must use

Purpose:

## Segment Group Summary:

<u>Pos</u>	<u>Tag</u>	<u>Segment Name</u>	<u>Status</u>	<u>Rep</u>	<u>Usage</u>
0380	CUX	CURRENCIES	M	1	Must use

# CUX CURRENCIES

Pos: 0380	Max: 1
Mandatory	
Group: 7	Elements: 4

**User Option (Usage):** Must use

**Purpose:** To specify currencies used in the transaction and relevant details for the rate of exchange.

## Element Summary:

<u>Ref</u>	<u>Tag</u>	<u>Element Name</u>	<u>Status</u>	<u>Type</u>	<u>Min/Max</u>	<u>Usage</u>
CUX010	C504	<b>CURRENCY DETAILS</b>	C	Comp		Must use
CUX010-01 0	6347	<b>Currency details qualifier</b>	M	an	1/3	Must use
<b>CodeList Summary</b> (Total Codes: 7, Included: 1)						
<b>Code Name</b>						
2 Reference currency						
CUX010-02 0	6345	<b>Currency, coded</b>	C	an	1/3	Must use
CUX010-03 0	6343	<b>Currency qualifier</b>	C	an	1/3	Must use
<b>CodeList Summary</b> (Total Codes: 18, Included: 1)						
<b>Code Name</b>						
10 Pricing currency						
* CUX010-04 0	6348	<b>Currency rate base</b>	C	n	1/4	Not used
CUX020	C504	<b>CURRENCY DETAILS</b>	C	Comp		Must use
CUX020-01 0	6347	<b>Currency details qualifier</b>	M	an	1/3	Must use
<b>CodeList Summary</b> (Total Codes: 7, Included: 1)						
<b>Code Name</b>						
3 Target currency						
CUX020-02 0	6345	<b>Currency, coded</b>	C	an	1/3	Must use
CUX020-03 0	6343	<b>Currency qualifier</b>	C	an	1/3	Must use
<b>CodeList Summary</b> (Total Codes: 18, Included: 1)						
<b>Code Name</b>						
11 Payment currency						
* CUX020-04 0	6348	<b>Currency rate base</b>	C	n	1/4	Not used
CUX030	5402	<b>Rate of exchange</b>	C	n	1/12	Must use
* CUX040	6341	<b>Currency market exchange, coded</b>	C	an	1/3	Not used

## Segment example for customer:

*CUX+2:DKK:10+3:DKK:11+1000000'*

## Segment Group 8

Pos: 0400	Repeat: 10
Conditional	
Group: 8	Elements: N/A

**User Option (Usage):** Must use

**Purpose:**

### Segment Group Summary:

<u>Pos</u>	<u>Tag</u>	<u>Segment Name</u>	<u>Status</u>	<u>Rep</u>	<u>Usage</u>
0410	PAT	PAYMENT TERMS BASIS	M	1	Must use
0420	DTM	DATE/TIME/PERIOD	C	5	Must use

**PAT PAYMENT TERMS BASIS**

Pos: 0410	Max: 1
Mandatory	
Group: 8	Elements: 3

**User Option (Usage):** Must use**Purpose:** To specify the payment terms basis.**Element Summary:**

<u>Ref</u>	<u>Tag</u>	<u>Element Name</u>	<u>Status</u>	<u>Type</u>	<u>Min/Max</u>	<u>Usage</u>
PAT010	4279	Payment terms type qualifier	M	an	1/3	Must use
<b>CodeList Summary</b> (Total Codes: 38, Included: 1)						
<b>Code Name</b>						
3 Fixed date						
* PAT020	C110	<b>PAYMENT TERMS</b>	C	Comp		Not used
* PAT020-010	4277	<b>Terms of payment identification</b>	M	an	1/17	Not used
* PAT020-020	1131	<b>Code list qualifier</b>	C	an	1/3	Not used
* PAT020-030	3055	<b>Code list responsible agency, coded</b>	C	an	1/3	Not used
* PAT020-040	4276	<b>Terms of payment</b>	C	an	1/35	Not used
* PAT020-050	4276	<b>Terms of payment</b>	C	an	1/35	Not used
* PAT030	C112	<b>TERMS/TIME INFORMATION</b>	C	Comp		Not used
* PAT030-010	2475	<b>Payment time reference, coded</b>	M	an	1/3	Not used
* PAT030-020	2009	<b>Time relation, coded</b>	C	an	1/3	Not used
* PAT030-030	2151	<b>Type of period, coded</b>	C	an	1/3	Not used
* PAT030-040	2152	<b>Number of periods</b>	C	n	1/3	Not used

**Segment example for customer:**

PAT+3'

**DTM DATE/TIME/PERIOD**

Pos: 0420	Max: 5
Conditional	
Group: 8	Elements: 1

**User Option (Usage):** Must use

**Purpose:** To specify date, and/or time, or period.

**Element Summary:**

<u>Ref</u>	<u>Tag</u>	<u>Element Name</u>	<u>Status</u>	<u>Type</u>	<u>Min/Max</u>	<u>Usage</u>
DTM010	C507	DATE/TIME/PERIOD	M	Comp		Must use
DTM010-01 0	2005	Date/time/period qualifier	M	an	1/3	Must use

**CodeList Summary** (Total Codes: 485, Included: 1)

**Code Name**

13 Terms net due date

DTM010-02 0	2380	Date/time/period	C	an	1/35	Must use
DTM010-03 0	2379	Date/time/period format qualifier	C	an	1/3	Must use

**CodeList Summary** (Total Codes: 71, Included: 1)

**Code Name**

102 CCYYMMDD

**Segment example for customer:**

*DTM+13:20100428:102'*

# Segment Group 26

<b>Pos: 1060</b>	<b>Repeat: 9999999</b>
<b>Conditional</b>	
<b>Group: 26</b>	<b>Elements: N/A</b>

**User Option (Usage):** Must use

**Purpose:**

## Segment Group Summary:

<u>Pos</u>	<u>Tag</u>	<u>Segment Name</u>	<u>Status</u>	<u>Rep</u>	<u>Usage</u>
1070	LIN	LINE ITEM	M	1	Must use
1100	MEA	MEASUREMENTS	C	5	Must use
1210		Segment Group 27	C	10	Must use
1350		Segment Group 30	C	10	Must use
1380		Segment Group 31	C	10	Must use
1550		Segment Group 35	C	99	Must use
1670		Segment Group 39	C	30	Must use



**LIN LINE ITEM**

<b>Pos: 1070</b>	<b>Max: 1</b>
<b>Mandatory</b>	
<b>Group: 26</b>	<b>Elements: 6</b>

**User Option (Usage):** Must use

**Purpose:** To identify a line item and configuration.

**Element Summary:**

<u>Ref</u>	<u>Tag</u>	<u>Element Name</u>	<u>Status</u>	<u>Type</u>	<u>Min/Max</u>	<u>Usage</u>
LIN010	1082	Line item number	C	an	1/6	Must use
* LIN020	1229	Action request/notification, coded	C	an	1/3	Not used
* LIN030	C212	ITEM NUMBER IDENTIFICATION	C	Comp		Not used
* LIN030-010	7140	Item number	C	an	1/35	Not used
* LIN030-020	7143	Item number type, coded	C	an	1/3	Not used
* LIN030-030	1131	Code list qualifier	C	an	1/3	Not used
* LIN030-040	3055	Code list responsible agency, coded	C	an	1/3	Not used
* LIN040	C829	SUB-LINE INFORMATION	C	Comp		Not used
* LIN040-010	5495	Sub-line indicator, coded	C	an	1/3	Not used
* LIN040-020	1082	Line item number	C	an	1/6	Not used
* LIN050	1222	Configuration level	C	n	1/2	Not used
* LIN060	7083	Configuration, coded	C	an	1/3	Not used

**Segment example for customer:**

LIN+1'

# MEA MEASUREMENTS

Pos: 1100	Max: 5
Conditional	
Group: 26	Elements: 4

**User Option (Usage):** Must use

**Purpose:** To specify physical measurements, including dimension tolerances, weights and counts.

## Element Summary:

<u>Ref</u>	<u>Tag</u>	<u>Element Name</u>	<u>Status</u>	<u>Type</u>	<u>Min/Max</u>	<u>Usage</u>
MEA010	6311	<b>Measurement purpose qualifier</b>	M	an	1/3	Must use
<b>CodeList Summary</b> (Total Codes: 86, Included: 4)						
<b>Code Name</b>						
WT Weights						
CHW Chargeable weight						
LMT Loading meters						
VOL Volume						
MEA020	C502	<b>MEASUREMENT DETAILS</b>	C	Comp		Used
MEA020-01 0	6313	<b>Property measured, coded</b>	C	an	1/3	Must use
<b>CodeList Summary</b> (Total Codes: 244, Included: 1)						
<b>Code Name</b>						
AAD Total gross weight						
* MEA020-02 0	6321	<b>Measurement significance, coded</b>	C	an	1/3	Not used
* MEA020-03 0	6155	<b>Measurement attribute identification</b>	C	an	1/17	Not used
* MEA020-04 0	6154	<b>Measurement attribute</b>	C	an	1/70	Not used
MEA030	C174	<b>VALUE/RANGE</b>	C	Comp		Must use
MEA030-01 0	6411	<b>Measure unit qualifier</b>	M	an	1/3	Must use
MEA030-02 0	6314	<b>Measurement value</b>	C	an	1/18	Must use
* MEA030-03 0	6162	<b>Range minimum</b>	C	n	1/18	Not used
* MEA030-04 0	6152	<b>Range maximum</b>	C	n	1/18	Not used
* MEA030-05 0	6432	<b>Significant digits</b>	C	n	1/2	Not used
* MEA040	7383	<b>Surface/layer indicator, coded</b>	C	an	1/3	Not used

## Segment example for customer:

```
MEA+WT+AAD+KGM:68.000'
MEA+CHW++KGM:79.587'
MEA+VOL++CBM:0.239'
MEA+LMT++MTR:0.000'
```

# Segment Group 27

Pos: 1210	Repeat: 10
Conditional	
Group: 27	Elements: N/A

User Option (Usage): Must use

Purpose:

## Segment Group Summary:

<u>Pos</u>	<u>Tag</u>	<u>Segment Name</u>	<u>Status</u>	<u>Rep</u>	<u>Usage</u>
1220	MOA	MONETARY AMOUNT	M	1	Must use

# MOA MONETARY AMOUNT

Pos: 1220	Max: 1
Mandatory	
Group: 27	Elements: 1

**User Option (Usage):** Must use

**Purpose:** To specify a monetary amount.

## Element Summary:

<u>Ref</u>	<u>Tag</u>	<u>Element Name</u>	<u>Status</u>	<u>Type</u>	<u>Min/Max</u>	<u>Usage</u>
MOA010	C516	MONETARY AMOUNT	M	Comp		Must use
MOA010-01 0	5025	Monetary amount type qualifier	M	an	1/3	Must use
<b>CodeList Summary</b> (Total Codes: 402, Included: 1)						
<b>Code Name</b>						
203 Line item amount						
MOA010-02 0	5004	Monetary amount	C	n	1/35	Must use
MOA010-03 0	6345	Currency, coded	C	an	1/3	Must use
* MOA010-04 0	6343	Currency qualifier	C	an	1/3	Not used
* MOA010-05 0	4405	Status, coded	C	an	1/3	Not used

## Segment example for customer:

MOA+203:372.000:DKK'

---

# Segment Group 30

Pos: 1350	Repeat: 10
Conditional	
Group: 30	Elements: N/A

**User Option (Usage):** Must use

**Purpose:**

## Segment Group Summary:

<u>Pos</u>	<u>Tag</u>	<u>Segment Name</u>	<u>Status</u>	<u>Rep</u>	<u>Usage</u>
1360	RFF	REFERENCE	M	1	Must use

# RFF REFERENCE

Pos: 1360	Max: 1
Mandatory	
Group: 30	Elements: 1

**User Option (Usage):** Must use

**Purpose:** To specify a reference.

## Element Summary:

<u>Ref</u>	<u>Tag</u>	<u>Element Name</u>	<u>Status</u>	<u>Type</u>	<u>Min/Max</u>	<u>Usage</u>
RFF010	C506	REFERENCE	M	Comp		Must use
RFF010-010	1153	Reference qualifier	M	an	1/3	Must use
<b>CodeList Summary</b> (Total Codes: 618, Included: 2)						
<b>Code Name</b>						
BN Booking reference number						
CU Consignor's reference number						
RFF010-020	1154	Reference number	C	an	1/35	Must use
* RFF010-030	1156	Line number	C	an	1/6	Not used
* RFF010-040	4000	Reference version number	C	an	1/35	Not used
* RFF010-050	1060	Revision number	C	an	1/6	Not used

## Segment example for customer:

RFF+BN:KEYHO-47497'  
RFF+CU:0001320194'

---

# Segment Group 31

Pos: 1380	Repeat: 10
Conditional	
Group: 31	Elements: N/A

**User Option (Usage):** Must use

**Purpose:**

## Segment Group Summary:

<u>Pos</u>	<u>Tag</u>	<u>Segment Name</u>	<u>Status</u>	<u>Rep</u>	<u>Usage</u>
1390	PAC	PACKAGE	M	1	Must use

# PAC PACKAGE

Pos: 1390	Max: 1
Mandatory	
Group: 31	Elements: 5

**User Option (Usage):** Must use

**Purpose:** To describe the number and type of packages/physical units.

## Element Summary:

<u>Ref</u>	<u>Tag</u>	<u>Element Name</u>	<u>Status</u>	<u>Type</u>	<u>Min/Max</u>	<u>Usage</u>
PAC010	7224	Number of packages	C	n	1/8	Must use
* PAC020	C531	<b>PACKAGING DETAILS</b>	C	Comp		Not used
* PAC020-010	7075	Packaging level, coded	C	an	1/3	Not used
* PAC020-020	7233	Packaging related information, coded	C	an	1/3	Not used
* PAC020-030	7073	Packaging terms and conditions, coded	C	an	1/3	Not used
PAC030	C202	<b>PACKAGE TYPE</b>	C	Comp		Must use
PAC030-010	7065	Type of packages identification	C	an	1/17	Must use
* PAC030-020	1131	Code list qualifier	C	an	1/3	Not used
* PAC030-030	3055	Code list responsible agency, coded	C	an	1/3	Not used
* PAC030-040	7064	Type of packages	C	an	1/35	Not used
* PAC040	C402	<b>PACKAGE TYPE IDENTIFICATION</b>	C	Comp		Not used
* PAC040-010	7077	Item description type, coded	M	an	1/3	Not used
* PAC040-020	7064	Type of packages	M	an	1/35	Not used
* PAC040-030	7143	Item number type, coded	C	an	1/3	Not used
* PAC040-040	7064	Type of packages	C	an	1/35	Not used
* PAC040-050	7143	Item number type, coded	C	an	1/3	Not used
* PAC050	C532	<b>RETURNABLE PACKAGE DETAILS</b>	C	Comp		Not used
* PAC050-010	8395	Returnable package freight payment responsibility, coded	C	an	1/3	Not used
* PAC050-020	8393	Returnable package load contents, coded	C	an	1/3	Not used

## Segment example for customer:

PAC+2++CLL'



---

# Segment Group 35

Pos: 1550	Repeat: 99
Conditional	
Group: 35	Elements: N/A

**User Option (Usage):** Must use

**Purpose:**

## Segment Group Summary:

<u>Pos</u>	<u>Tag</u>	<u>Segment Name</u>	<u>Status</u>	<u>Rep</u>	<u>Usage</u>
1560	NAD	NAME AND ADDRESS	M	1	Must use

# NAD NAME AND ADDRESS

Pos: 1560	Max: 1
Mandatory	
Group: 35	Elements: 9

**User Option (Usage):** Must use

**Purpose:** To specify the name/address and their related function, either by CO82 only and/or unstructured by CO58 or structured by CO80 thru 3207.

## Element Summary:

<u>Ref</u>	<u>Tag</u>	<u>Element Name</u>	<u>Status</u>	<u>Type</u>	<u>Min/Max</u>	<u>Usage</u>
NAD010	3035	Party qualifier	M	an	1/3	Must use

**CodeList Summary** (Total Codes: 375, Included: 4)

### Code Name

CN	Consignee
CZ	Consignor
DP	Delivery party
PW	Despatch party

NAD020	C082	<b>PARTY IDENTIFICATION DETAILS</b>	C	Comp		Used
NAD020-01 0	3039	<b>Party identification</b>	M	an	1/35	Must use
* NAD020-02 0	1131	<b>Code list qualifier</b>	C	an	1/3	Not used
* NAD020-03 0	3055	<b>Code list responsible agency, coded</b>	C	an	1/3	Not used
* NAD030	C058	<b>NAME AND ADDRESS</b>	C	Comp		Not used
* NAD030-01 0	3124	<b>Name and address line</b>	M	an	1/35	Not used
* NAD030-02 0	3124	<b>Name and address line</b>	C	an	1/35	Not used
* NAD030-03 0	3124	<b>Name and address line</b>	C	an	1/35	Not used
* NAD030-04 0	3124	<b>Name and address line</b>	C	an	1/35	Not used
* NAD030-05 0	3124	<b>Name and address line</b>	C	an	1/35	Not used
NAD040	C080	<b>PARTY NAME</b>	C	Comp		Must use
NAD040-01 0	3036	<b>Party name</b>	M	an	1/35	Must use
* NAD040-02 0	3036	<b>Party name</b>	C	an	1/35	Not used
* NAD040-03 0	3036	<b>Party name</b>	C	an	1/35	Not used
* NAD040-04 0	3036	<b>Party name</b>	C	an	1/35	Not used
* NAD040-05 0	3036	<b>Party name</b>	C	an	1/35	Not used
* NAD040-06 0	3045	<b>Party name format, coded</b>	C	an	1/3	Not used

<u>Ref</u>	<u>Tag</u>	<u>Element Name</u>	<u>Status</u>	<u>Type</u>	<u>Min/Max</u>	<u>Usage</u>
NAD050	C059	<b>STREET</b>	C	Comp		Used
NAD050-01 0	3042	<b>Street and number/p.o. box</b>	M	an	1/35	Must use
* NAD050-02 0	3042	<b>Street and number/p.o. box</b>	C	an	1/35	Not used
* NAD050-03 0	3042	<b>Street and number/p.o. box</b>	C	an	1/35	Not used
* NAD050-04 0	3042	<b>Street and number/p.o. box</b>	C	an	1/35	Not used
NAD060	3164	<b>City name</b>	C	an	1/35	Used
* NAD070	3229	<b>Country sub-entity identification</b>	C	an	1/9	Not used
NAD080	3251	<b>Postcode identification</b>	C	an	1/9	Used
NAD090	3207	<b>Country, coded</b>	C	an	1/3	Used

### Segment example for customer:

*NAD+CZ+050000165474++MAN DIESEL+NIELS JUELS VEJ 15+FREDERIKSHAVN++9900+DK'*  
*NAD+PW+050000165474++MAN DIESEL+NIELS JUELS VEJ 15+FREDERIKSHAVN++9900+DK'*  
*NAD+CN+000000000000++VAN ESCH SSL++ROTTERDAM++3089 KB+NL'*  
*NAD+DP+++VAN ESCH SSL++ROTTERDAM++3089 KB+NL'*

# Segment Group 39

Pos: 1670	Repeat: 30
Conditional	
Group: 39	Elements: N/A

User Option (Usage): Must use

Purpose:

## Segment Group Summary:

<u>Pos</u>	<u>Tag</u>	<u>Segment Name</u>	<u>Status</u>	<u>Rep</u>	<u>Usage</u>
1680	ALC	ALLOWANCE OR CHARGE	M	1	Must use
1780		Segment Group 42	C	2	Must use
1860		Segment Group 44	C	5	Must use

**ALC ALLOWANCE OR CHARGE**

Pos: 1680	Max: 1
Mandatory	
Group: 39	Elements: 5

**User Option (Usage):** Must use**Purpose:** To identify allowance or charge details.**Element Summary:**

<u>Ref</u>	<u>Tag</u>	<u>Element Name</u>	<u>Status</u>	<u>Type</u>	<u>Min/Max</u>	<u>Usage</u>
ALC010	5463	Allowance or charge qualifier	M	an	1/3	Must use
<b>CodeList Summary</b> (Total Codes: 24, Included: 1)						
<b>Code Name</b>						
C Charge						
ALC020	C552	ALLOWANCE/CHARGE INFORMATION	C	Comp		Must use
* ALC020-010	1230	Allowance or charge number	C	an	1/35	Not used
ALC020-020	5189	Charge/allowance description, coded	C	an	1/3	Must use
<b>CodeList Summary</b> (Total Codes: 58, Included: 1)						
<b>Code Name</b>						
6 Advising commission						
* ALC030	4471	Settlement, coded	C	an	1/3	Not used
* ALC040	1227	Calculation sequence indicator, coded	C	an	1/3	Not used
ALC050	C214	SPECIAL SERVICES IDENTIFICATION	C	Comp		Must use
ALC050-010	7161	Special services, coded	C	an	1/3	Must use
<b>CodeList Summary</b> (Total Codes: 268, Included: 1)						
<b>Code Name</b>						
ACT Non-standard surcharge						
* ALC050-020	1131	Code list qualifier	C	an	1/3	Not used
ALC050-030	3055	Code list responsible agency, coded	C	an	1/3	Must use
<b>CodeList Summary</b> (Total Codes: 223, Included: 1)						
<b>Code Name</b>						
87 Assigned by carrier						
ALC050-040	7160	Special service	C	an	1/35	Must use
* ALC050-050	7160	Special service	C	an	1/35	Not used

**Segment example for customer:**

ALC+C+:6+++ACT::87:KAM FEE'

---

# Segment Group 42

Pos: 1780	Repeat: 2
Conditional	
Group: 42	Elements: N/A

User Option (Usage): Must use

Purpose:

## Segment Group Summary:

<u>Pos</u>	<u>Tag</u>	<u>Segment Name</u>	<u>Status</u>	<u>Rep</u>	<u>Usage</u>
1790	MOA	MONETARY AMOUNT	M	1	Must use

# MOA MONETARY AMOUNT

Pos: 1790	Max: 1
Mandatory	
Group: 42	Elements: 1

**User Option (Usage):** Must use

**Purpose:** To specify a monetary amount.

## Element Summary:

<u>Ref</u>	<u>Tag</u>	<u>Element Name</u>	<u>Status</u>	<u>Type</u>	<u>Min/Max</u>	<u>Usage</u>
MOA010	C516	<b>MONETARY AMOUNT</b>	M	Comp		Must use
MOA010-01 0	5025	<b>Monetary amount type qualifier</b>	M	an	1/3	Must use

**CodeList Summary** (Total Codes: 402, Included: 2)

**Code Name**

8 Allowance or charge amount  
124 Tax amount

MOA010-02 0	5004	<b>Monetary amount</b>	C	n	1/35	Must use
MOA010-03 0	6345	<b>Currency, coded</b>	C	an	1/3	Must use
* MOA010-04 0	6343	<b>Currency qualifier</b>	C	an	1/3	Not used
* MOA010-05 0	4405	<b>Status, coded</b>	C	an	1/3	Not used

## Segment example for customer:

MOA+8:95.000:DKK'  
MOA+124:23.750:DKK'

# Segment Group 44

Pos: 1860	Repeat: 5
Conditional	
Group: 44	Elements: N/A

User Option (Usage): Must use

Purpose:

## Segment Group Summary:

<u>Pos</u>	<u>Tag</u>	<u>Segment Name</u>	<u>Status</u>	<u>Rep</u>	<u>Usage</u>
1870	TAX	DUTY/TAX/FEE DETAILS	M	1	Must use



# TAX DUTY/TAX/FEE DETAILS

Pos: 1870	Max: 1
Mandatory	
Group: 44	Elements: 7

**User Option (Usage):** Must use

**Purpose:** To specify relevant duty/tax/fee information.

## Element Summary:

<u>Ref</u>	<u>Tag</u>	<u>Element Name</u>	<u>Status</u>	<u>Type</u>	<u>Min/Max</u>	<u>Usage</u>
TAX010	5283	Duty/tax/fee function qualifier	M	an	1/3	Must use
CodeList Summary (Total Codes: 8, Included: 1)						
<u>Code</u> <u>Name</u>						
7 Tax						
TAX020	C241	DUTY/TAX/FEE TYPE	C	Comp		Must use
TAX020-010	5153	Duty/tax/fee type, coded	C	an	1/3	Must use
CodeList Summary (Total Codes: 45, Included: 1)						
<u>Code</u> <u>Name</u>						
VAT Value added tax						
* TAX020-020	1131	Code list qualifier	C	an	1/3	Not used
* TAX020-030	3055	Code list responsible agency, coded	C	an	1/3	Not used
* TAX020-040	5152	Duty/tax/fee type	C	an	1/35	Not used
* TAX030	C533	DUTY/TAX/FEE ACCOUNT DETAIL	C	Comp		Not used
* TAX030-010	5289	Duty/tax/fee account identification	M	an	1/6	Not used
* TAX030-020	1131	Code list qualifier	C	an	1/3	Not used
* TAX030-030	3055	Code list responsible agency, coded	C	an	1/3	Not used
* TAX040	5286	Duty/tax/fee assessment basis	C	an	1/15	Not used
TAX050	C243	DUTY/TAX/FEE DETAIL	C	Comp		Must use
* TAX050-010	5279	Duty/tax/fee rate identification	C	an	1/7	Not used
* TAX050-020	1131	Code list qualifier	C	an	1/3	Not used
* TAX050-030	3055	Code list responsible agency, coded	C	an	1/3	Not used
TAX050-040	5278	Duty/tax/fee rate	C	an	1/17	Must use
* TAX050-050	5273	Duty/tax/fee rate basis identification	C	an	1/12	Not used
* TAX050-060	1131	Code list qualifier	C	an	1/3	Not used
* TAX050-070	3055	Code list responsible agency, coded	C	an	1/3	Not used
TAX060	5305	Duty/tax/fee category, coded	C	an	1/3	Must use
CodeList Summary (Total Codes: 13, Included: 1)						
<u>Code</u> <u>Name</u>						
S Standard rate						

\* TAX070    3446    **Party tax identification number**    C    an    1/20    Not used

**Segment example for customer:**

*TAX+7+VAT+++:::25,0000+S'*

# UNS SECTION CONTROL

Pos: 2120	Max: 1
Mandatory	
Group:	Elements: 1
N/A	

**User Option (Usage):** Must use

**Purpose:** To separate header, detail, and summary sections of a message.

## Element Summary:

<u>Ref</u>	<u>Tag</u>	<u>Element Name</u>	<u>Status</u>	<u>Type</u>	<u>Min/Max</u>	<u>Usage</u>
UNS010	0081	Section identification	M	a	1/1	Must use

**CodeList Summary** (Total Codes: 2, Included: 1)

Code Name

S Detail/summary section separation

## Segment example for customer:

*UNS+S'*

---

# Segment Group 50

Pos: 2140	Repeat: 100
Mandatory	
Group: 50	Elements: N/A

User Option (Usage): Must use

Purpose:

## Segment Group Summary:

<u>Pos</u>	<u>Tag</u>	<u>Segment Name</u>	<u>Status</u>	<u>Rep</u>	<u>Usage</u>
2150	MOA	MONETARY AMOUNT	M	1	Must use

**MOA MONETARY AMOUNT**

Pos: 2150	Max: 1
Mandatory	
Group: 50	Elements: 1

**User Option (Usage):** Must use**Purpose:** To specify a monetary amount.**Element Summary:**

<u>Ref</u>	<u>Tag</u>	<u>Element Name</u>	<u>Status</u>	<u>Type</u>	<u>Min/Max</u>	<u>Usage</u>
MOA010	C516	<b>MONETARY AMOUNT</b>	M	Comp		Must use
MOA010-01 0	5025	<b>Monetary amount type qualifier</b>	M	an	1/3	Must use

**CodeList Summary** (Total Codes: 402, Included: 3)**Code Name**

86 Message total monetary amount  
 125 Taxable amount  
 176 Message total duty/tax/fee amount

MOA010-02 0	5004	<b>Monetary amount</b>	C	n	1/35	Must use
MOA010-03 0	6345	<b>Currency, coded</b>	C	an	1/3	Must use
* MOA010-04 0	6343	<b>Currency qualifier</b>	C	an	1/3	Not used
* MOA010-05 0	4405	<b>Status, coded</b>	C	an	1/3	Not used

**Segment example for customer:**

MOA+125:372.000:DKK'  
 MOA+86:465.000:DKK'  
 MOA+176:93.000:DKK'

# Segment Group 52

Pos: 2190	Repeat: 10
Conditional	
Group: 52	Elements: N/A

User Option (Usage): Must use

Purpose:

## Segment Group Summary:

<u>Pos</u>	<u>Tag</u>	<u>Segment Name</u>	<u>Status</u>	<u>Rep</u>	<u>Usage</u>
2200	TAX	DUTY/TAX/FEE DETAILS	M	1	Must use

# TAX DUTY/TAX/FEE DETAILS

Pos: 2200	Max: 1
Mandatory	
Group: 52	Elements: 7

**User Option (Usage):** Must use

**Purpose:** To specify relevant duty/tax/fee information.

## Element Summary:

<u>Ref</u>	<u>Tag</u>	<u>Element Name</u>	<u>Status</u>	<u>Type</u>	<u>Min/Max</u>	<u>Usage</u>
TAX010	5283	Duty/tax/fee function qualifier	M	an	1/3	Must use
<b>CodeList Summary</b> (Total Codes: 8, Included: 1)						
<b>Code Name</b>						
	7	Tax				
TAX020	C241	DUTY/TAX/FEE TYPE	C	Comp		Must use
TAX020-010	5153	Duty/tax/fee type, coded	C	an	1/3	Must use
<b>CodeList Summary</b> (Total Codes: 45, Included: 1)						
<b>Code Name</b>						
	VAT	Value added tax				
* TAX020-020	1131	Code list qualifier	C	an	1/3	Not used
* TAX020-030	3055	Code list responsible agency, coded	C	an	1/3	Not used
* TAX020-040	5152	Duty/tax/fee type	C	an	1/35	Not used
* TAX030	C533	DUTY/TAX/FEE ACCOUNT DETAIL	C	Comp		Not used
* TAX030-010	5289	Duty/tax/fee account identification	M	an	1/6	Not used
* TAX030-020	1131	Code list qualifier	C	an	1/3	Not used
* TAX030-030	3055	Code list responsible agency, coded	C	an	1/3	Not used
* TAX040	5286	Duty/tax/fee assessment basis	C	an	1/15	Not used
TAX050	C243	DUTY/TAX/FEE DETAIL	C	Comp		Must use
* TAX050-010	5279	Duty/tax/fee rate identification	C	an	1/7	Not used
* TAX050-020	1131	Code list qualifier	C	an	1/3	Not used
* TAX050-030	3055	Code list responsible agency, coded	C	an	1/3	Not used
TAX050-040	5278	Duty/tax/fee rate	C	an	1/17	Must use
* TAX050-050	5273	Duty/tax/fee rate basis identification	C	an	1/12	Not used
* TAX050-060	1131	Code list qualifier	C	an	1/3	Not used
* TAX050-070	3055	Code list responsible agency, coded	C	an	1/3	Not used
TAX060	5305	Duty/tax/fee category, coded	C	an	1/3	Must use
<b>CodeList Summary</b> (Total Codes: 13, Included: 1)						
<b>Code Name</b>						
	S	Standard rate				

\* TAX070    3446    **Party tax identification number**    C    an    1/20    Not used

**Segment example for customer:**

*TAX+7+VAT+++:::25,0000+S'*



# UNT MESSAGE TRAILER

Pos: 2270	Max: 1
Mandatory	
Group:	Elements: 2
N/A	

**User Option (Usage):** Must use

**Purpose:** To end and check the completeness of a message.

## Element Summary:

<u>Ref</u>	<u>Tag</u>	<u>Element Name</u>	<u>Status</u>	<u>Type</u>	<u>Min/Max</u>	<u>Usage</u>
UNT010	0074	Number of segments in a message	M	n	1/6	Must use
UNT020	0062	Message reference number	M	an	1/14	Must use

## Segment example for customer:

*UNT+37+1'*

# UNZ INTERCHANGE TRAILER

Pos:	Max: 1
Mandatory	
Group:	Elements: 2
N/A	

**User Option (Usage):** Must use

**Purpose:** To end and check the completeness of an interchange.

### Element Summary:

<u>Ref</u>	<u>Tag</u>	<u>Element Name</u>	<u>Status</u>	<u>Type</u>	<u>Min/Max</u>	<u>Usage</u>
UNZ010	0036	Interchange control count	M	n	1/6	Must use
UNZ020	0020	Interchange control reference	M	an	1/14	Must use

### Segment example for customer:

*UNZ+1+932'*